

# Software Requirement Specification For Digital Watch System

Team 4

김선우 이지우 김도연 신호혜

# Contents

A decorative graphic consisting of a vertical line and a horizontal line intersecting at the top of the list items.

**01 System Context Diagram**

**02 DFD Level 0**

**03 DFD Level 1**

**04 DFD Level 2**

**05 DFD Level 3**

**06 DFD Level 4 - State Transition Diagram**

**07 Overall DFD**

# System Context Diagram

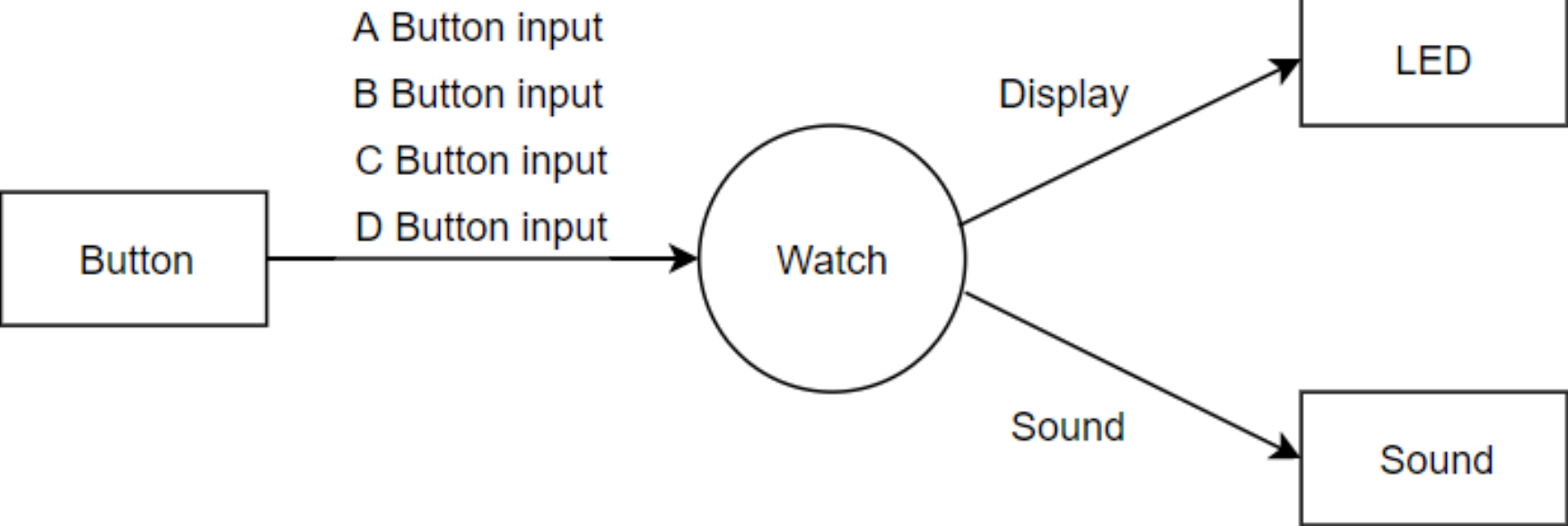

## Event List

Input / Output Event	Description
A Button input	A Button 입력
B Button input	B Button 입력
C Button input	C Button 입력
D Button input	D Button 입력
Display	LED에 Display Command, Backlight Command를 전달
Sound	Sound에 Beep Command를 전달

## DFD Level 0

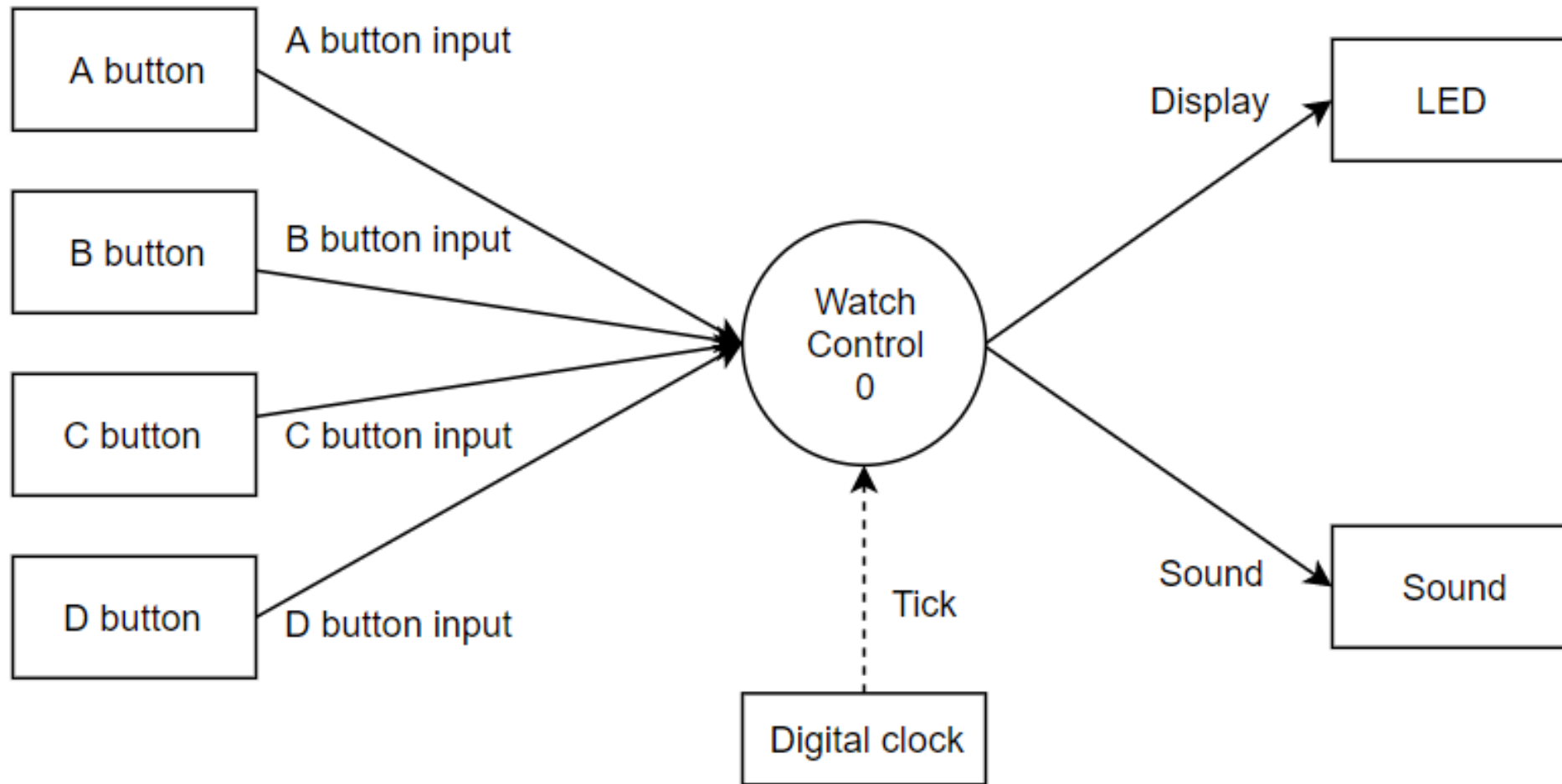

## Data Dictionary

Input / Output Event	Description	Format / Type
A Button input	A Button 입력을 물리적으로 감지	True/False, Interrupt
B Button input	B Button 입력을 물리적으로 감지	True/False, Interrupt
C Button input	C Button 입력을 물리적으로 감지	True/False, Interrupt
D Button input	D Button 입력을 물리적으로 감지	True/False, Interrupt
Display	LED에 Display Command, Backlight Command를 전달	String
Sound	Sound에 Beep Command를 전달	Beep

# DFD Level 1

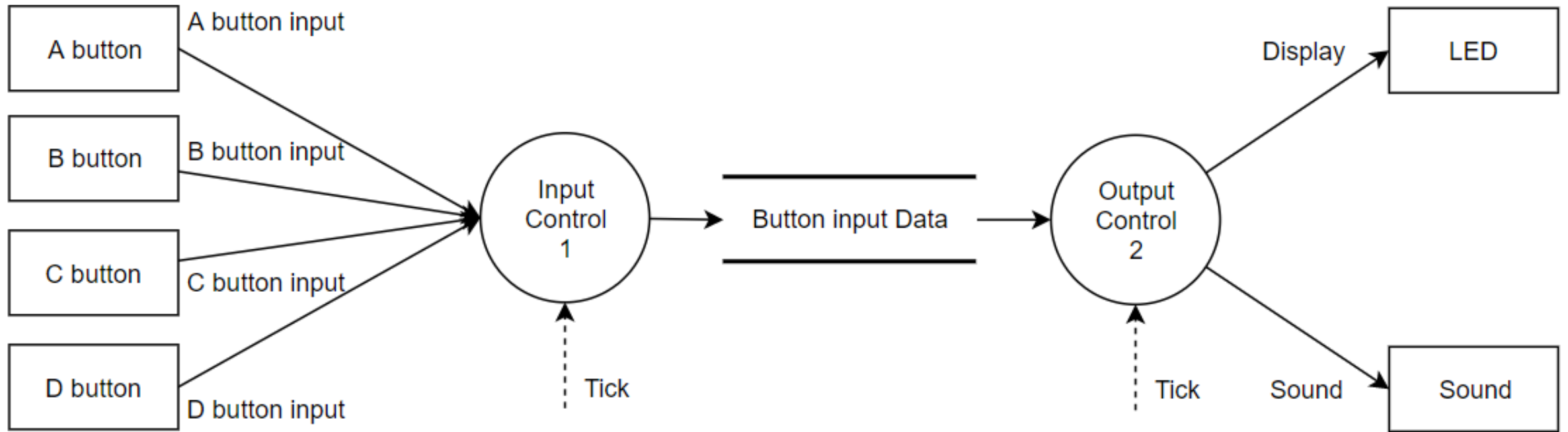

## + Data Dictionary

Input / Output Event	Description	Format / Type
Button input Data	A, B, C, D Button에서 받은 데이터를 기반으로 Input Control을 거쳐 받는 정보 (각 버튼에 대한 정보를 정수형으로 변환해 저장한다.)	Integer, periodic



# DFD Level 2

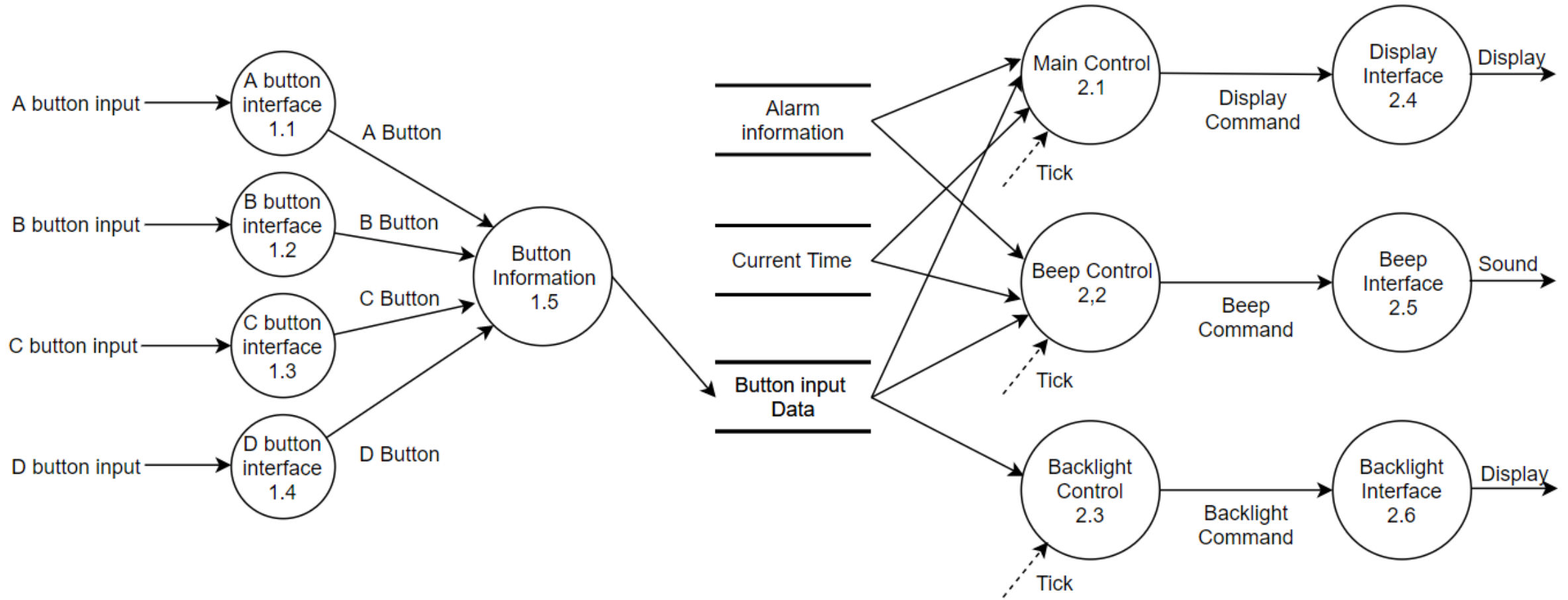

## + Data Dictionary

Input / Output Event	Description	Format / Type
Alarm information	알람 on/off, 알람 시간 등을 저장하는 data storage	Array, Interrupt
Current Time	현재 시간을 저장하는 data storage	Datetime, Periodic
Display Command	Main control에서 Display Interface에게 표시될 정보와 함께 출력 신호를 전달	String, Periodic
Beep Command	Beep Control에서 Beep Interface로 신호 전달	Beep, Interrupt
Backlight Command	Backlight Control에서 Backlight Interface로 신호 전달	True/False, Interrupt
Display	Display Interface, Backlight Interface의 출력	String
Sound	Beep Interface의 출력	Beep

# DFD Level 3 - Main Controller

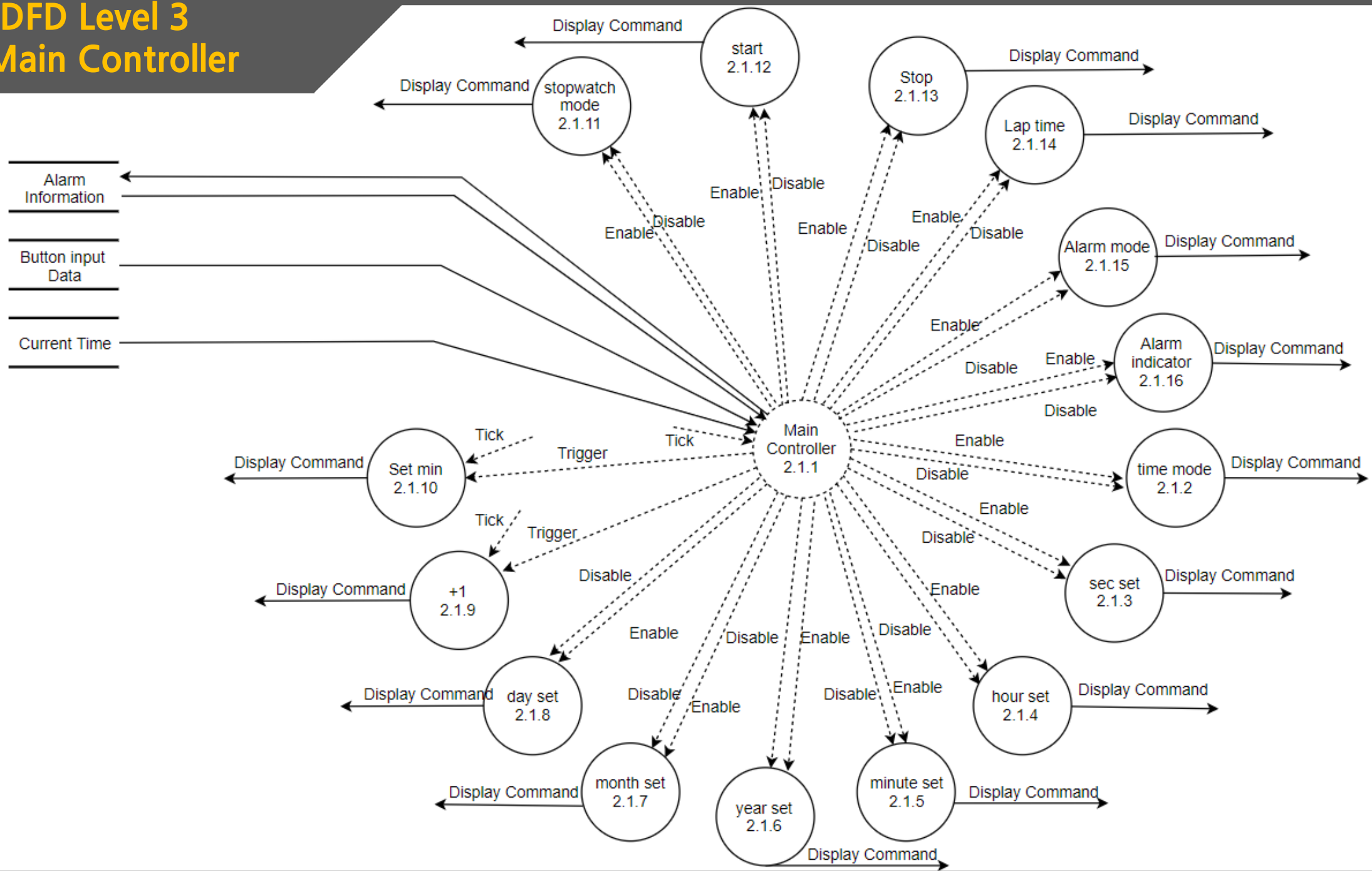

## + Data Dictionary

Input / Output Event	Description	Format / Type
Alarm Information	메인 컨트롤에서 제어된 알람에 대한 정보 (알람 ON/OFF, 알람 설정시간, 알람 모드, 알람 indicator)를 저장한다.	Array , Interrupt

# DFD Level 3 - Beep Controller

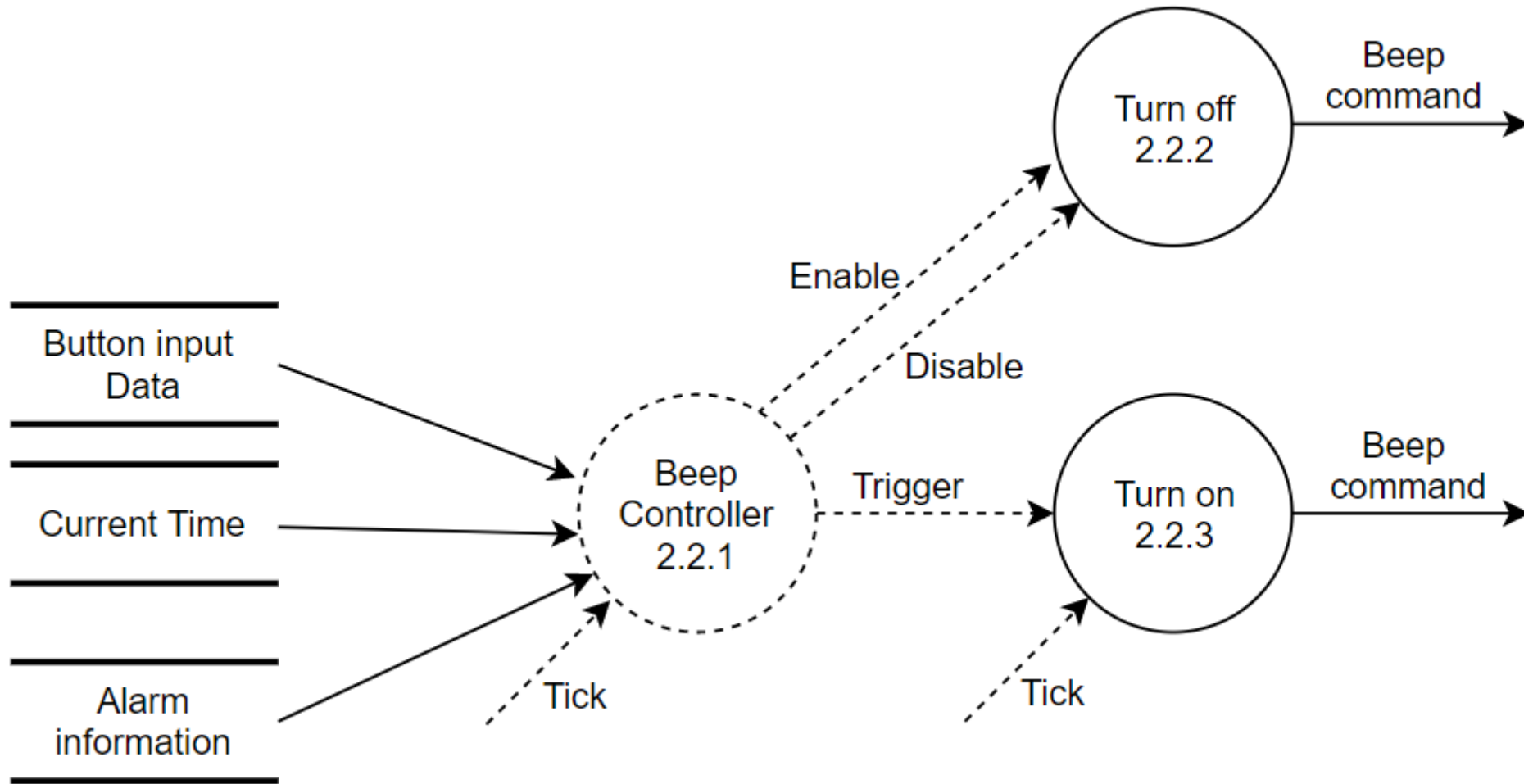

# DFD Level 3 - Backlight Controller

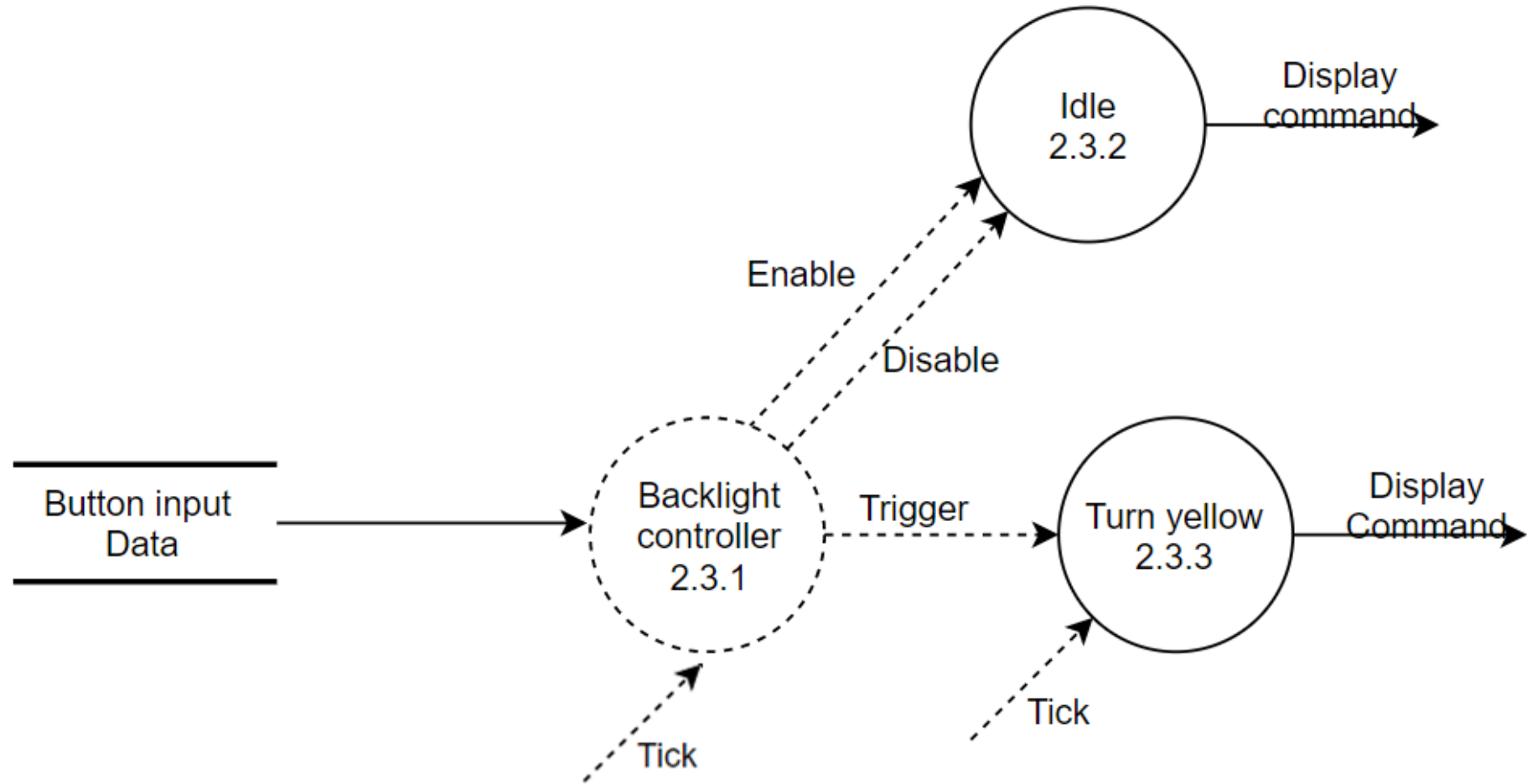

# DFD Level 4 - STD of Main Controller

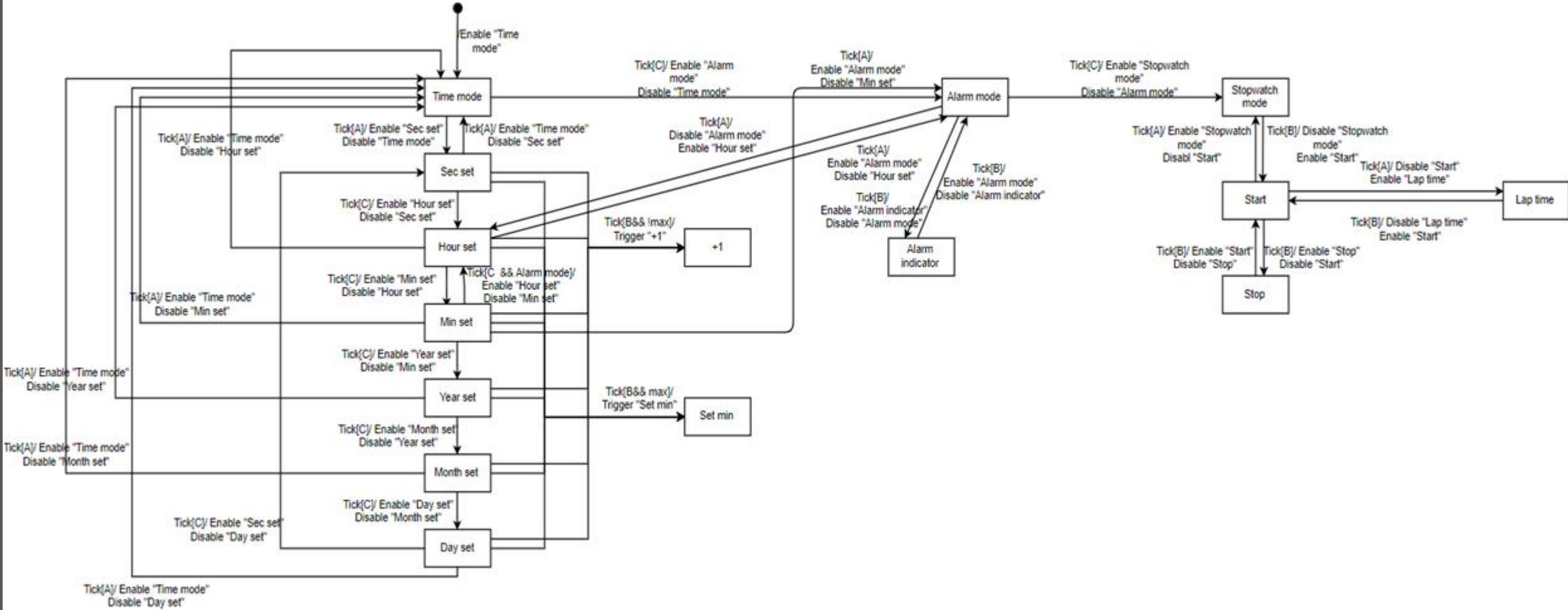

# DFD Level 4 - STD of Main Controller

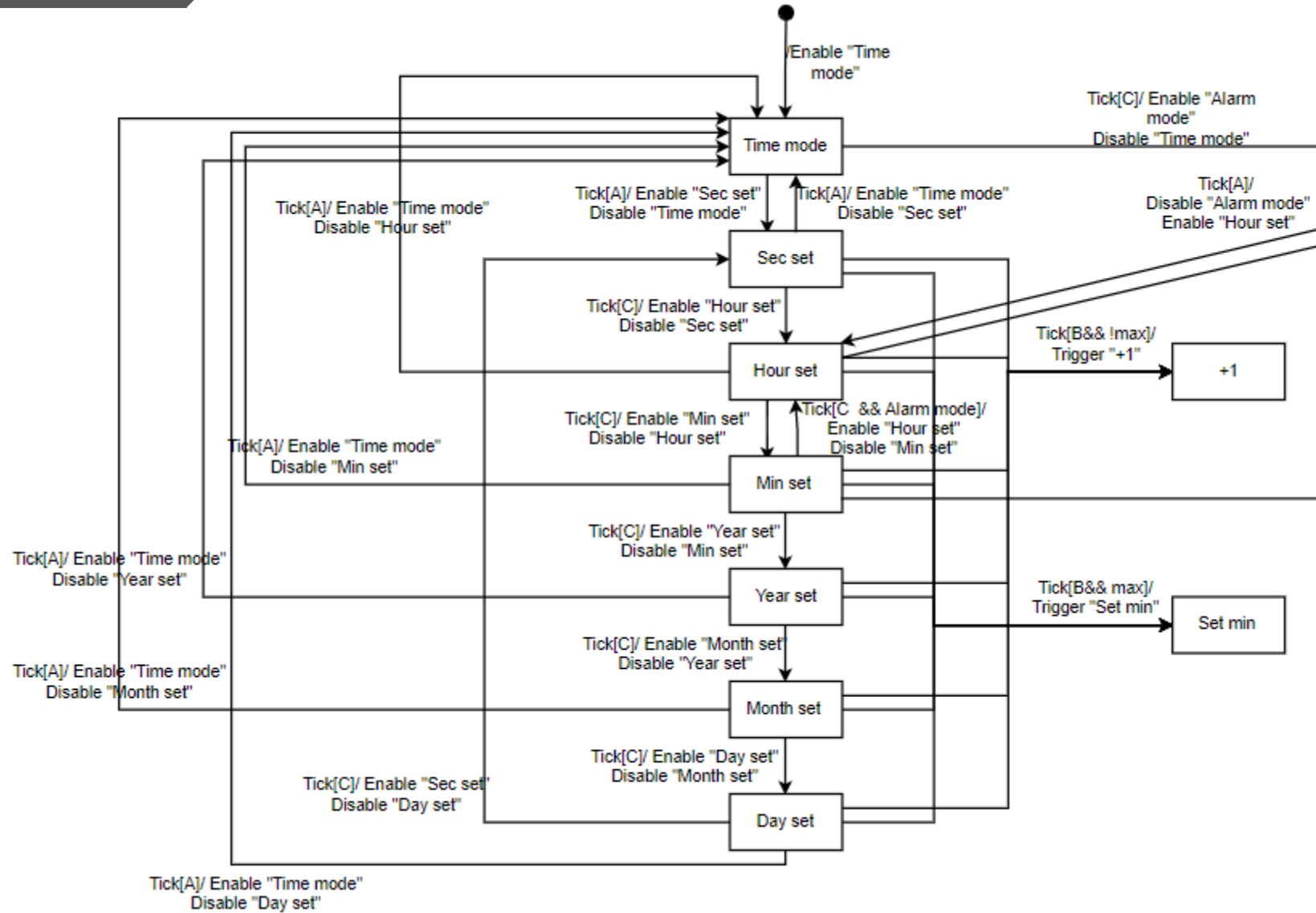



# DFD Level 4 - STD of Main Controller

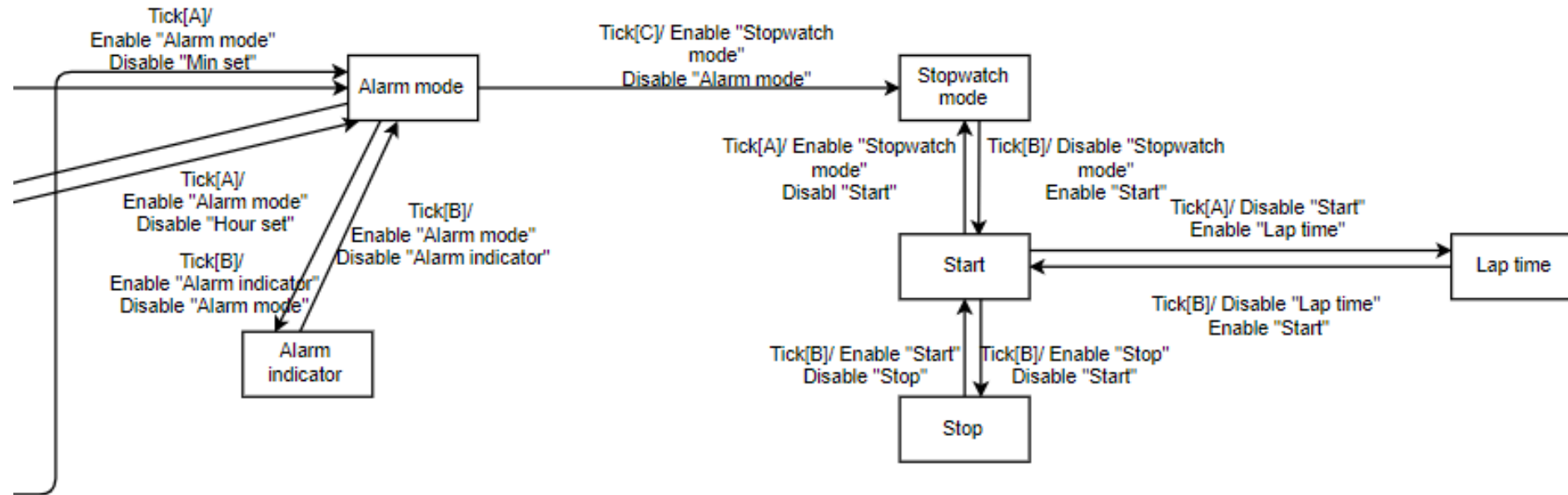

# DFD Level 4 - STD of Beep controller

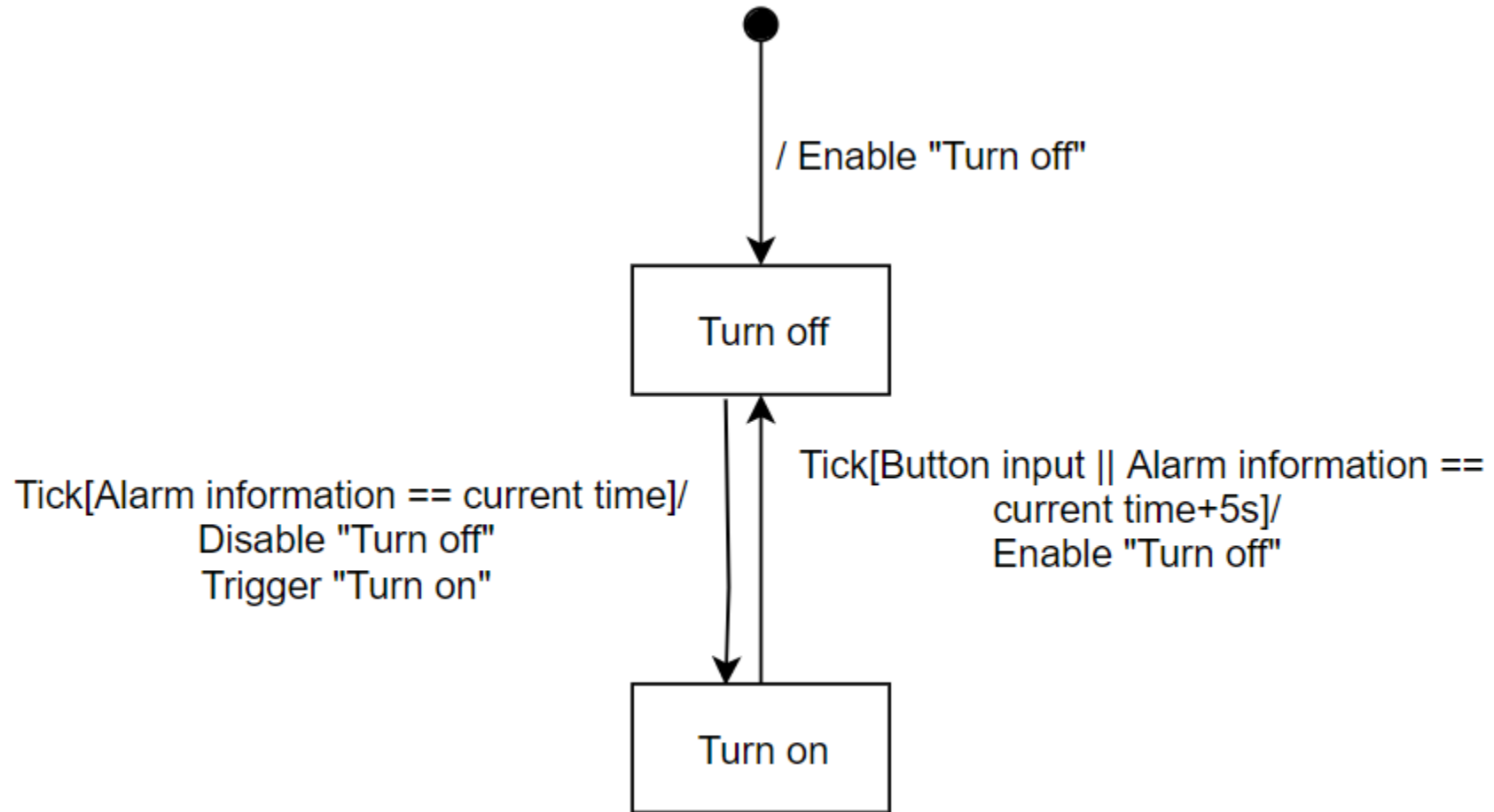

# DFD Level 4 - STD of Backlight controller

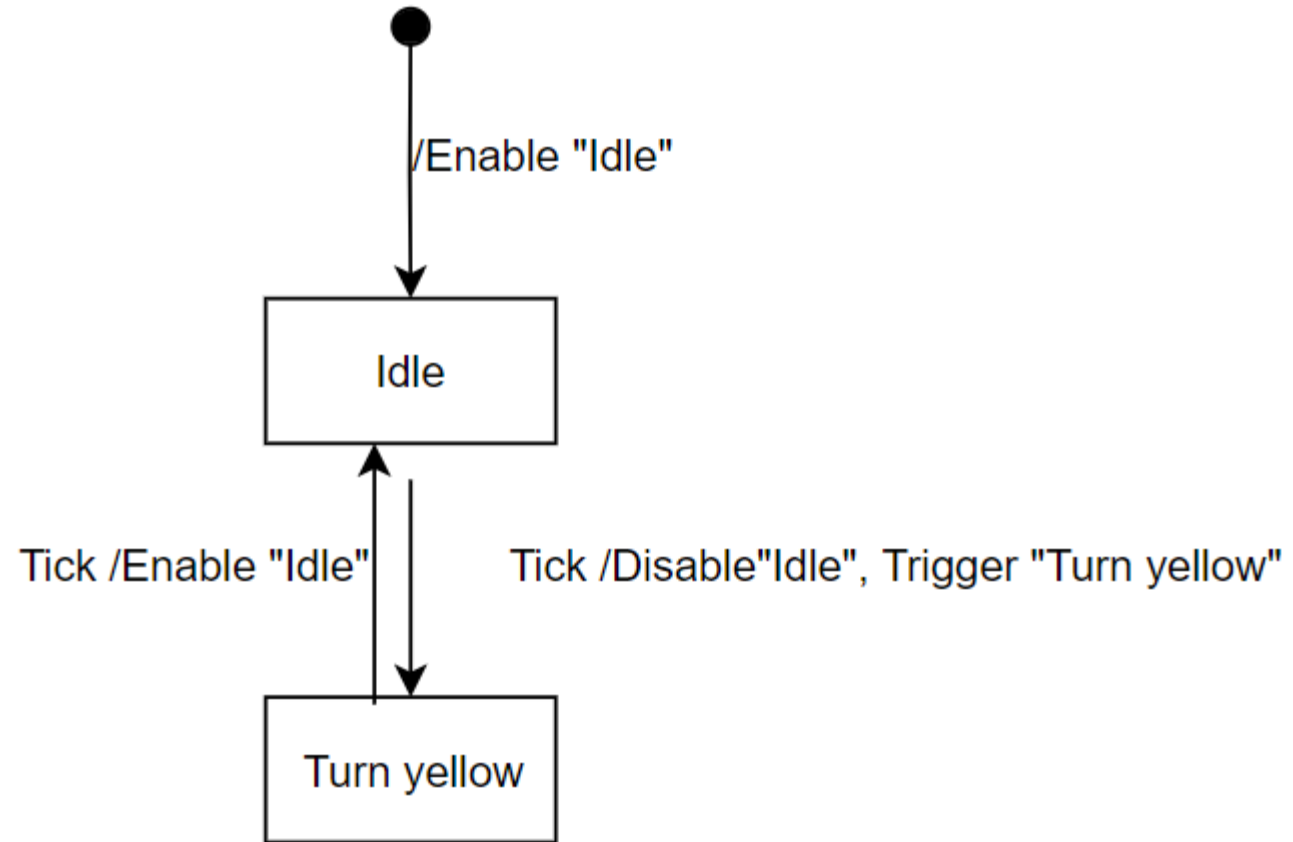

# Overall DFD

